



## OPERATION AND MAINTENANCE MANUAL FOR 4VN Series Hydraulic Pneumatic Pump



### ATW Hydraulic

It is operating manual of 4VN torque wrench air pump, please read carefully follow instructions、 warnings and cautions before using the tools.

#### Safety Guide

The hydraulic torque wrench pump's safe usage requires correct operation and regular inspect. And the user is requested to follow always and carefully .

▲ precaution to avoid direct loss in economic or property.

▲ warning to avoid personal injury.

Please follow herein before!

When using, if something abnormal happens, please shut off the power immediately, and then consult ATW or ATW's agent.

1. When using, do not permit any person stand at the oil output in order to avoid personal injury and equipment damage. Please put the pump far away from the fire.
2. Make sure that the hose and quick coupler be connected before building up the pressure in order to avoid hydraulic fluid spurting out to cause personal injury.
3. The maximum operating pressure of this pump is 700Bar(10,000Psi),ATW has set up the pressure to 70Mpa before selling this pump. Please do not adjust to a pressure higher than the maximum pressure which ATW has not set.
4. If this pump is used for operating other equipments, make sure the maximum operating pressure of the equipments will be less than 700Bar. Please adjust the pressure to which the equipment need, or else the equipment would be damaged.
5. Make sure the power of the pump is shut off before repairing it.
6. Please shut off the switch before starting power; if the switch is on, the pressure may increase.
7. Make sure the equipment be connected with ground to avoid electric shock.
8. Please do not change any part of the pump; if it must be changed, please inform ATW or ATW's agent for help. Without allowance of ATW or its agent, any refit of it will be out of our warranty range.
9. Please do not fill the pump reservoir with too much oil, otherwise, the pressure of the reservoir will increase and the oil will spill over, so the reservoir will be broken and the environment will be polluted.
10. Make sure the quick coupler is tightened; if the quick coupler is not tightened enough, the equipment will not work normally; if it is a synchronic system, the problem may cause one or several pieces of equipment out of order and the quick coupler may be broken and it may cause personal injury or equipment damage.
11. Please stand away from the position where the hydraulic oil may be spurt out; hydraulic oil may penetrate your hand and hurt you.
12. If the hydraulic oil splashed in your eyes, please immediately wash your eyes about 15 minutes with clean water, then you must go to hospital for help right now.
13. The wrench and power pump are connected by a 700 Bar operating pressure, twin-line hose assembly. Each end of the hose will have one male and one female connector to assure proper interconnection between pump and wrench.

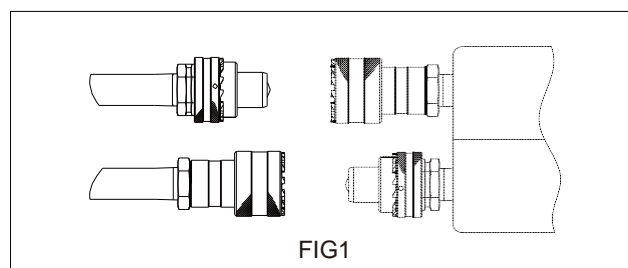

14. Please do not touch the pressurized hose; if the hydraulic oil splashed out, it will cause serious injury.
15. Hydraulic hose is easily spoiled fitting; you inspect the hose with eyes regularly and find no problems, but the inner side may have crack and small hole; ATW suggests you should change the hose regularly for

### PRECAUTION

1. Only ATW hydraulic special oil available.
2. Do not use pressure regulate valve as relief valve.
3. The used hydraulic oil should be put away according to the antipollution ordinance.

## DESCRIPTION

1. This pump is used for hydraulic torque wrench and fitted in integrated way, it is an independent hydraulic unit that mainly consists of pump, control valve, oil reservoir, motor, meter, control-line fitting, it has the peculiarity of small volume, light weight, simple composition, convenient operation, high working pressure. The pump can supply oil with one high and one low oil outlet at the same time, which could make a large quantity of oil outputting. On high pressure, the low pressure pump will automatically let oil return through the release flow valve, which can reduce power consumption, and the pressure of the outlet can be arbitrarily adjusted from 70 to 700 bar.

2. Hydraulic oil for this pump: 46# anti-wear hydraulic oil.

3. Environmental temperature for using this pump: -10~60 °C

4. Please use ATW's high pressure hose, high pressure coupler, and so on. The maximum operation pressure of high pressure hose for this pump is 1000Bar; please choose suitable system for it.

5. If you need to use attached hydraulic product for pump, please contact ATW's engineers.

6. Please do not use this pump around the fire.

7. Please do not adjust the pressure valve arbitrarily to avoid personal injury or equipment damage due to high pressure.

8. Please confirm that the voltage for this pump is the same as the voltage of using on the spot.

9. You'd better use the pump indoors, please protect the pump from rain if it is used outdoors.

## EXTERNAL DIMENSION AND DESCRIPTION OF PARTS

### 4VN

ITEM	NAME	ITEM	NAME
1	Oil Reservoir	11	Adjusting pressure regulator
2	Bolt		
3	Air motor	12	Oil level guage
4	Oily water separator	13	Oil leak port
5	The air input valve	14	Screw
6	Radiator	15	Cover plate
7	Air valve	16	Oil port
8	Pressure gauge		
9	Frame For Protecting		
10	Quick coupler		

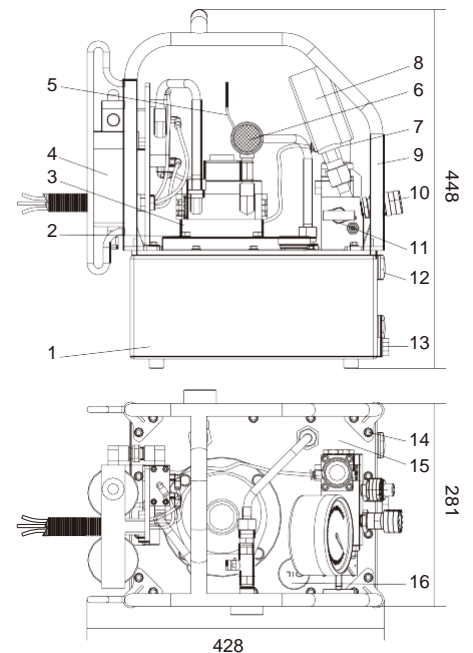

## DESCRIPTIONS OF PARTS

1. Oil reservoir: to store hydraulic oil, make sure there is enough oil to keep the pump working normally.

2. Bolt: to connect motor and oil reservoir.

3. Air Motor: provide power, 4~8Bar

4. Oily water separator: separator the oil and water from the air.

5. The air input valve: to let the low pressure air into system.

6. Radiator: to exclude the heat, ensure the operating time and life of the pump.

7. Air valve: its function is output oil when the pressure is very high, control the flow when oil return, and so on. It can be used to the maximum pressure and protect system to work normally at the set up pressure. The threads of oil output port is NPT 1/4`.
8. Pressure gauge: its range is 0~700Bar(0~10,000psi), in other words, the maximum operating pressure of this pump is 700Bar(10,000psi).
9. Frame for protecting: it is fixed on motor for carrying conveniently.
10. Quick coupler: its effect is for oil output or oil returning, also it can help people connect pump and tool with the hose quickly.
11. The adjusting pressure regulator: it can control the maximum operating pressure for this pump or set up the pressure for operating the tool. prohibit to adjust this valve arbitrarily.
12. Oil level measurer: it can help us know the oil level, when the oil less than the 1/3 of total, please fill the especial oil for hydraulic tools of ATW.
13. Release oil port: G1/4` thread, discharging the hydraulic oil from oil reservoir (when changing hydraulic oil)
14. Hex head screw: tight coupling oil reservoir.
15. Cover plate: air-tight seal of the oil reservoir.
16. Oil filter port: before you fill the oil in the oil reservoir, please loosen down the cover. There is a filter inside the port for keeping oil in the oil reservoir cleanness. Also there is an operating on the cover for releasing the air from oil reservoir.

## CHARACTERISTIC

1. 4VN is three-stage pump. Pressure relief valve is assembled in the high pressure port. the rated pressure in the low pressure port is 50-70Bar, And the flow is 1.4 L/min under 700Bar.
2. Max operating pressure: 700Bar
3. Flow: three-stage, can simultaneity use 4 torque wrenches
4. Motor: 4~8Bar air pressure motor
5. Environmental temperature: -10~80°C
6. Reservoir dimension: 448×428×281mm
7. Weight (No oil) : 4VN : 20.5Kg
8. Hydraulic oil: ISO VG 46#

## WARNING!!!

1. When operating, do not permit anyone stand at the oil output, The oil output must connect other components when adjusting the pressure.
2. When using, do not overpass the max operating pressure.
3. If need to check motor tank, please shut off the pump.
4. When working, the oil back to oil reservoir may add the pressure. If open the cover plate, unnecessary injury and damage will happen.
5. Prohibit to operate without oil
6. Keep the clean of the pump, clean especially the oil inlet, quick couplers.
7. Suggestion: in the condition of not using the pump always, please remember to replace the hydraulic oil

## MAINTENANCE AND INSPECTION

### 1. The inspection before operating

(1).Please shut off the pump and inspect whether the position of the power connection is loose or not. If it is loose, please tighten it.

(2).Please inspect whether the hydraulic oil in the oil reservoir is enough or not, if it is not enough, please fill the oil in time.

(3).The pump is still working when the direction of the air valve is changed, please build up pressure and inspect whether the whole equipment is normal or not.

(4).Please inspect whether the house and other equipments are leaky or not, if this happened, please inspect to find the reason and repair it or replace it.

### 2.The inspection in operation

When inspecting the following items, if there is abnormal situation, please shut off the pump and repair it.

(1)Please inspect whether there are abnormal condition or not in the course of raising the pressure.

(2)Please inspect whether the houses and other equipments are leaky or not.

(3)Please inspect whether there is some abnormal noise, rocking and smell or not during the operation of the air motor.

(4)Please inspect whether the temperature of hydraulic oil is too high or not.

### 3.The inspection after finishing the operation of the pump.

(1)Making sure the pump must be turn down.

(2)Please inspect whether there are leaky or abnormal condition or not. If there is abnormal situation,please inspect to find the reason and repair it

(3)Please clean it after using the pump.

### 4.Refer to changing the hydraulic oil

The oil should be replaced once a year principally. If there are following abnormal conditions, please replace the oil immediately.

(1)If dust mixes with the oil, please replace the oil.

(2)If there is abnormal smell, please replace the oil.

(3)If the water mixes with the oil, the colour of the oil has been changed into milkiness, please replace the oil.

(4)If the colour of the oil has been changed into black-brown, please replace the oil.

### 5.The way replacing the hydraulic oil

(1)Please loosen the oil filler port of oil reservoir.

(2)Please take down the screw on the flank of the oil reservoir, let hydraulic oil out.

(3)Please clean the inner and filter of the oil reservoir.

(4)Please install the screw and fill the oil reservoir with the hydraulic oil.

**WARNING:** If the oil splashes into your eyes, please wash with clean water for at least 15 minutes, and Then see doctor immediately. If the oil splashes to your skin, please wash it with clean water and soap.

**WARNING:** Waste hydraulic oil bellows to industrial waste, it should be dealt with by special companies.

## Noise/Vibration And Transport information

### 1、 Hydraulic pump noise declaration

1) Hydraulic pump noise value:  $\leq 70\text{db}$

### 2、 Hydraulic transport information. pump

1) Handle with care.

2) The shipment should be vertical upward, as shown in the FIG -2.

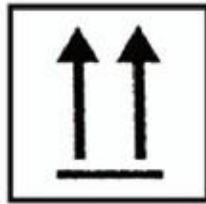

**FIG - 2**

3) Product handling, generally using portable, car handling and lifting and moving, as shown in the FIG-3.

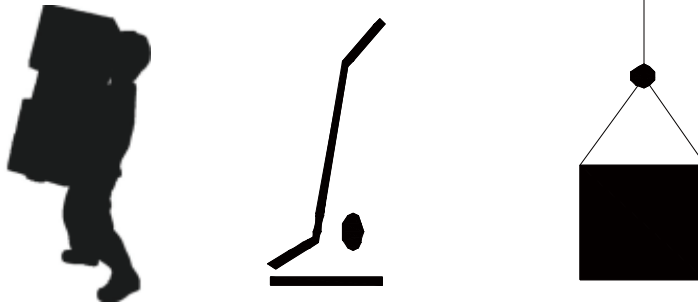

**FIG - 3**

## OPERATION INSTRUCTIONS

1.4VN hydraulic power pump is designed for hydraulic torque wrench. There is a 2-way, 4-position Air control valve on the pump, port A is high pressure point, it can export the oil at the high pressure, and port B is low pressure point which can return the oil at the low pressure.

(1) Please loosen the valve for adjusting pressure before operating.

(2) Please connect the air line and press the air input valve on the flank of the pump to make the pump start working and oil exporting.

(3) Please press the working button on the controller and adjust the pressure unit the working pressure reach to what you need, and then loosen the working button on the controller.

(4) When the desired pressure is reached, the motor stops working, and the pressure will keep the same. when the pressure falls down, the motor starts to work again.

(5) When the motor is working, if you press the "off" button on the pump, the motor stops working, the piston and pressure will also be stopped at the position when the motor stopped working, even if the pressure fell, the motor would not work again.

(6) After operating, please press the rubber button on the top of the air control valve in order to release the pressure in hoses and equipments, then you can take down the hose and cover the Safety cap for the quick couplers.

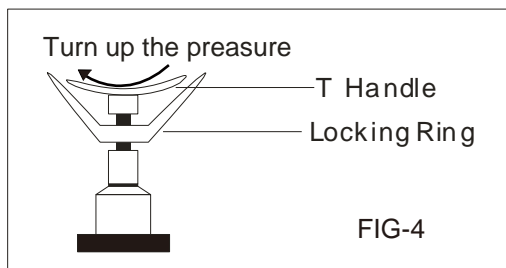

## TROUBLE SHOOTING GUIDE OF HYDRAULIC PUMP

The pump can't be started	The voltage isn't suitable	Confirming whether the voltage is suitable for the pump's need
	The power hasn't be connected	Checked the input air, switch and distribution box and so on, and connect the air.
The system has no pressure	The quick coupler hasn't be connected to the correct position	Take down and reinstall it
	No oil in the oil reservoir	Fill in oil
	Not enough oil in the oil reservoir	Fill in oil
	If the system has a throttle and hand single-direction valve, please check if the valve are open	Open the throttle and hand single-direction valve, and make sure the system is a circle
After reinstalling the quick coupler, the system has no pressure	The quick coupler can't be connected to the correct position, which causes no pressure in the system	Take down the quick coupler, check if the ball is elastic with a rod, if it can't move, please knock it with a hammer to eliminate the mist hydraulic oil
Leakage in the quick coupler	The o ring and escape have worn out	Replace the quick coupler

The pressure can't reach to the set pressure	The relief valve is adjusted too low	Check with the gauge, and adjust the relief valve to the system set pressure
	Oil is mixed with water	Change oil
	Not enough oil in the reservoir	Fill in oil
	Suck in air to the system	Repeat operating the system with no load for several times to eliminate the air
	The throttle and hand single-direction valve haven't been tightened	Locking valve
	The throttle and hand single-direction valve haven't been adjusted to the correct position	Adjust to the correct position
	The throttle and hand single-direction valve have broken	Replace the valve
	There is foreign matter in the oil	Wash the pump valve and change clean oil
When using under static pressure, the pressure reduces slowly	The seal is out of control, please check all the seal	Replace the seal

# EXPLOSION OF 4VN PNEUMATIC PUMP

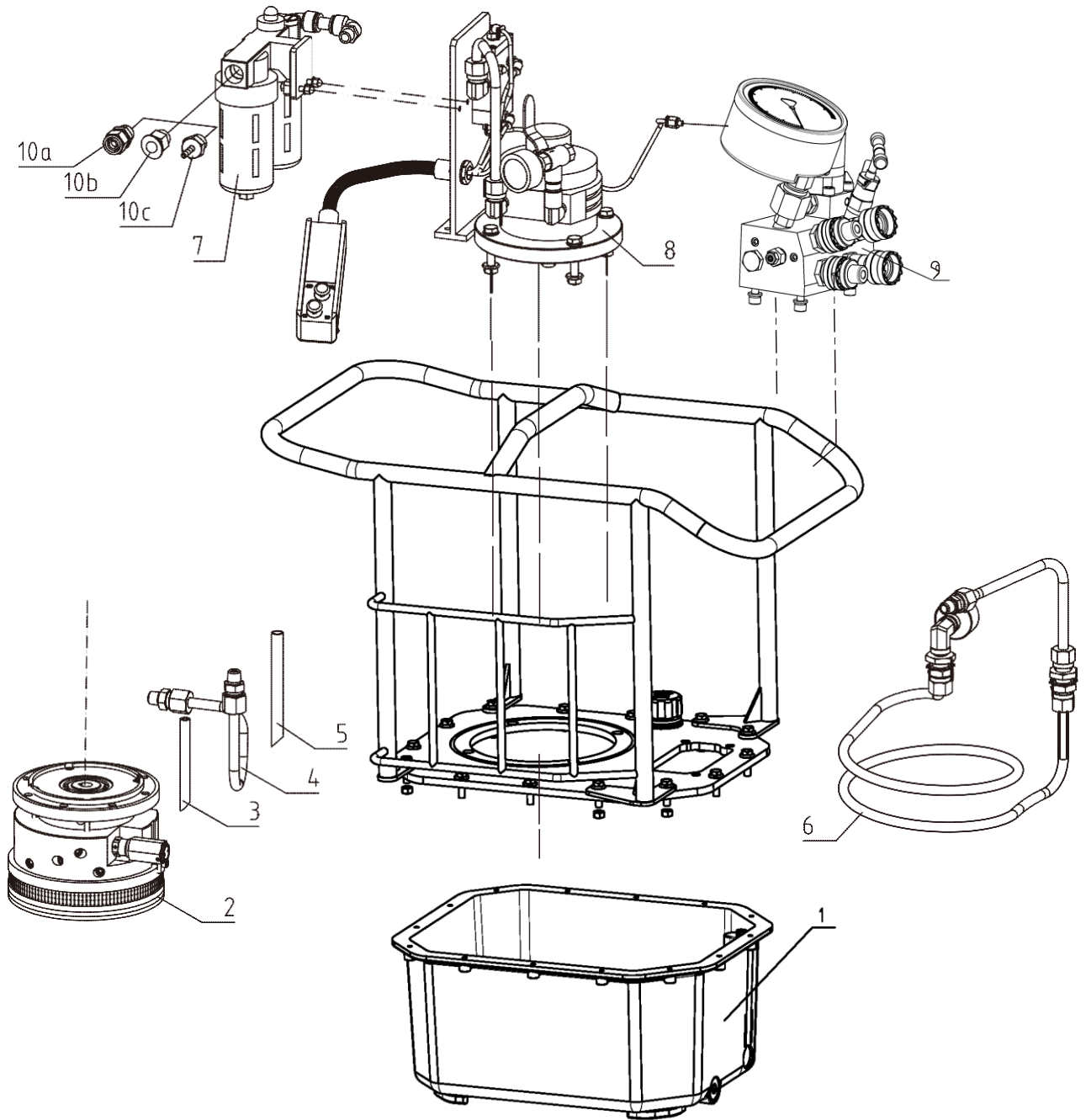

ITEM	NAME	ITEM	NAME
1	The tank module	7	Oily water separator
2	Pump module	8	Pneumatic control valve
3	Oil return pipe(1)	9	The type WE valve set module
4	Petroleum Pipeline	10	Fast screwed joint
5	Oil return pipe(2)	11	Straight thread joint
6	The cooler module	12	Copper fittings
			choose one

# EXPLOSION OF THE PUMP MODULE

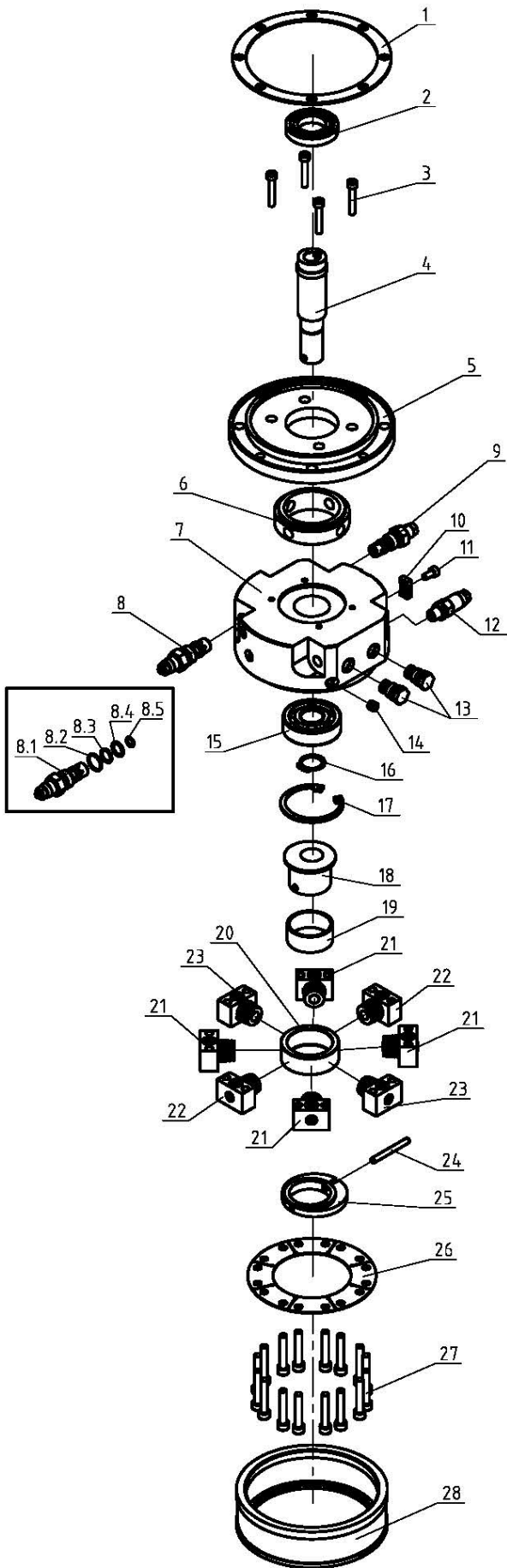

## Pump System

ITEM	PART NUMBER	DESCRIPTION	QTY
1	4VN-PS-1	Seal Gasket	1
2	4VN-PS-2	Ball Bearing	1
3	4VN-PS-3	Screw	4
4	4VN-PS-4	Connecting Bearing	1
5	4VN-PS-5	Body Flange	1
6	4VN-PS-6	Body Sleeve	1
7	4VN-PS-7	Pump Body	1
8	4VN-PS-8	Relief Valve Assembly	1
8.1	4VN-PS-8.1	Relief Valve	1
8.2	4VN-PS-8.2	O-Ring	1
8.3	4VN-PS-8.3	Retaining Ring	1
8.4	4VN-PS-8.4	O-Ring	1
8.5	4VN-PS-8.5	O-Ring	1
9	4VN-PS-9	Relief Valve Assembly	1
9.1	4VN-PS-9.1	Relief Valve	1
9.2	4VN-PS-9.2	O-Ring	1
9.3	4VN-PS-9.3	Retaining Ring	1
9.4	4VN-PS-9.4	O-Ring	1
9.5	4VN-PS-9.5	O-Ring	1
10	4VN-PS-10	Filter Fixer	1
11	4VN-PS-11	Screw	1
12	4VN-PS-12	Safety Valve Assembly	1
13	4VN-PS-13	Check Valve Assembly	2
13.1	4VN-PS-13.1	Check Valve	2
13.2	4VN-PS-13.2	Retaining Ring	2
13.3	4VN-PS-13.3	O-Ring	2
13.4	4VN-PS-13.4	O-Ring	2
14	4VN-PS-14	Plug Screw	12
15	4VN-PS-15	Ball Bearing	1
16	4VN-PS-16	Spring Clip	1
17	4VN-PS-17	Spring Clip	1
18	4VN-PS-18	Sleeve	1
19	4VN-PS-19	Copper Sleeve	1
20	4VN-PS-20	Bearing	1
21	4VN-PS-21	Piston 12mm	4
22	4VN-PS-22	Piston 7mm	2
23	4VN-PS-23	Piston 7mm	2
24	4VN-PS-24	Spring Pin	1
25	4VN-PS-25	Block	1
26	4VN-PS-26	Connecting Flange	1
27	4VN-PS-27	Screw	16
28	4VN-PS-28	Filter	1

# EXPLOSION OF THE TYPE WE VALVE SET MODULE

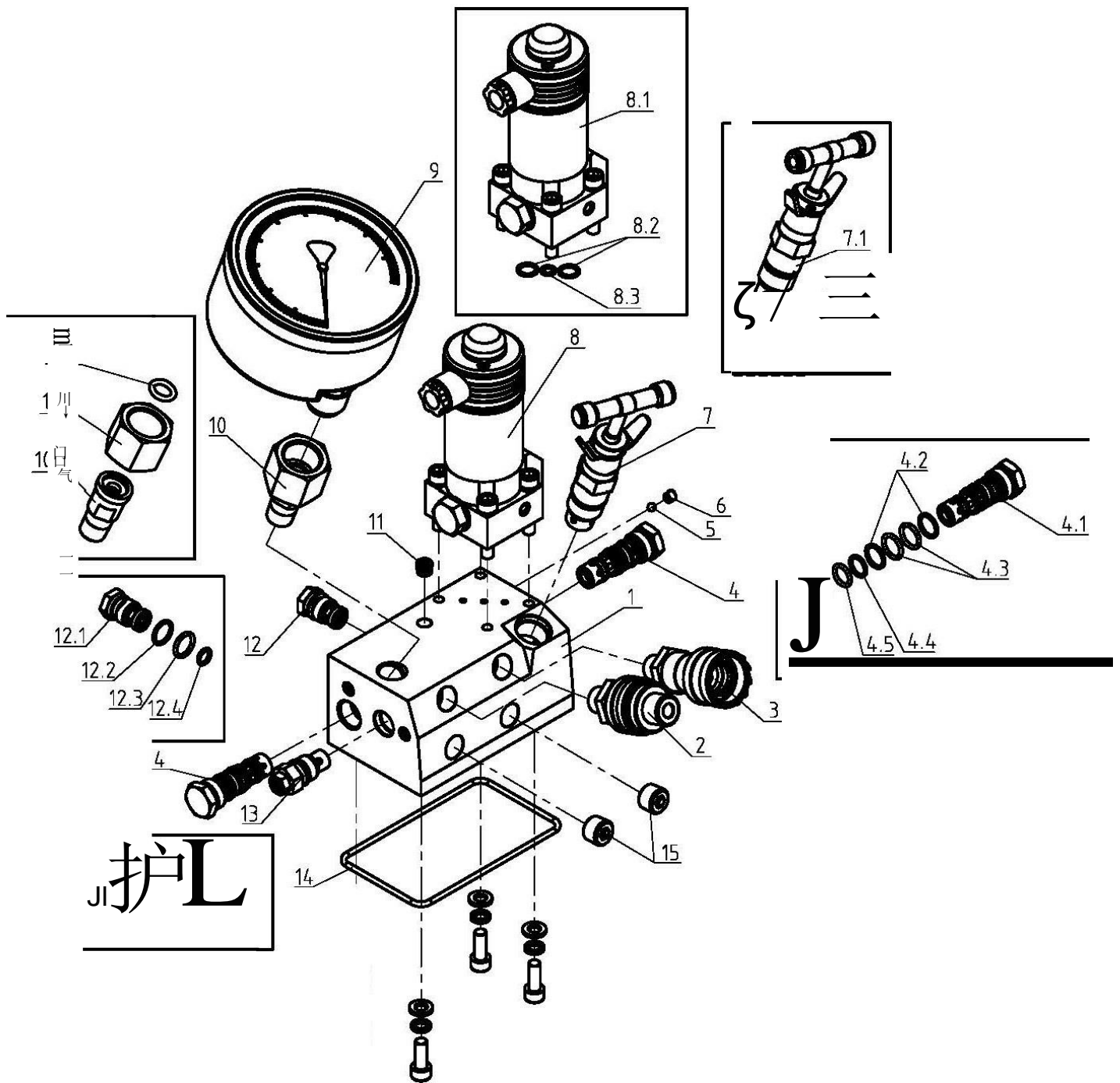

EXPLOSION OF THE TYPE 叭 /E VALVE SET MODULE

Valve System

1	J	4VN vs 1	J	Y.c:ti	1
2	J	4VNVS 3	J	Female Couple	2
4.1	J	4VN VS 4	J	Reversing Valve Assembly	2
4.2	J	"vN vs::i;?	J	Reversing Valve	2
4.3	J	L1VN vs::i;?	J	Retaining Ring	4
4.4	J	L1VN vs::i.4	J	O-Ring	4
4.5	J	"vN vs::i;\$.	J	Retaining Ring	2
4.6	J	L1YN-f.s-4.\$.	J	O-Ring	2
5	J	L1VN v\$ 5	J	O-Ring	2
5	J	4VN vs 6	J	Steel Ball screw	5
t	J	4VN-VS-7	J	Regulating Valve Assembly	1
7	J	4VN-VS-7.1	J	Regulating Valve	1
7.2	J	4VN-VS-7.2	J	O-Ring	1
7.3	J	4VN-VS-7.3	J	O-Ring	1
?	J	4VN-VS-8	J	Solenoid Valve Assembly	1
1.1	J	4VN-VS-8.1	J	Solenoid Valve	1
ii2	J	L1VN-VS-8.2	J	O-Ring	2
8.3	J	L1YN-f.s;?	J	O-Ring	1
9	J	N v\$	J	F.=>.r. G.到.9E:!	1
10	J	Y.f.J V 1Q	J	(:3.;ii,i9 itti 9 1y	1
10.1	J	4VN-VS-1.1.1	J	Q Ri_r:----- 1y	1
10.2	L	Y.N-Y.\$ 1.\$?	L	! =! lJ..9j::jtf/r.i9 且出. "	1
10.3	J	4VN-VS-10.3	J	Gauge Fitting	13
11	J	4VN-VS-11	J	Plug Screw	1
12	J	Y.N v 1.?	J	φhc:c:i<Y::i\ / 哽 r. 1y	1
12.1	J	vN-v\$ 1.2:1	J	φO y曹雪	1
12.2	J	L1YN vs-1.?2	J	c:ti_r:ii.n..9 11_9	1
12.3	J	4VN-vs-12.3	J	o Ri_r:-----	1
i?-4	J	4Y.N-Y.\$-f?4	J	φ.> 13.i.r:ii--	1
J?1	J	Y.N Y.\$fJ?	J	φ.> 13.i.r:ii--	1
J?..L	J	Y.N-Y.\$;J:i	J	9.-13!r::ig	1
J?..L	J	Y.N-Y.\$;J:i	J	9.-13!r::ig	1
1\$.	J	Y.N-Y.\$;J:i	J	13.i_rig	1
13.	J	Y.N-Y.\$;J:i	J	pg ? fr: -- +	1
1!	J	州扩 \$; 17	J	\$ .pr.i119 <:精	1
?	J	Y.N-Y.\$;J:i	J	\$scr..	1

# PNEUMATIC CONTROL MODULE EXPLODED DIAGRAM

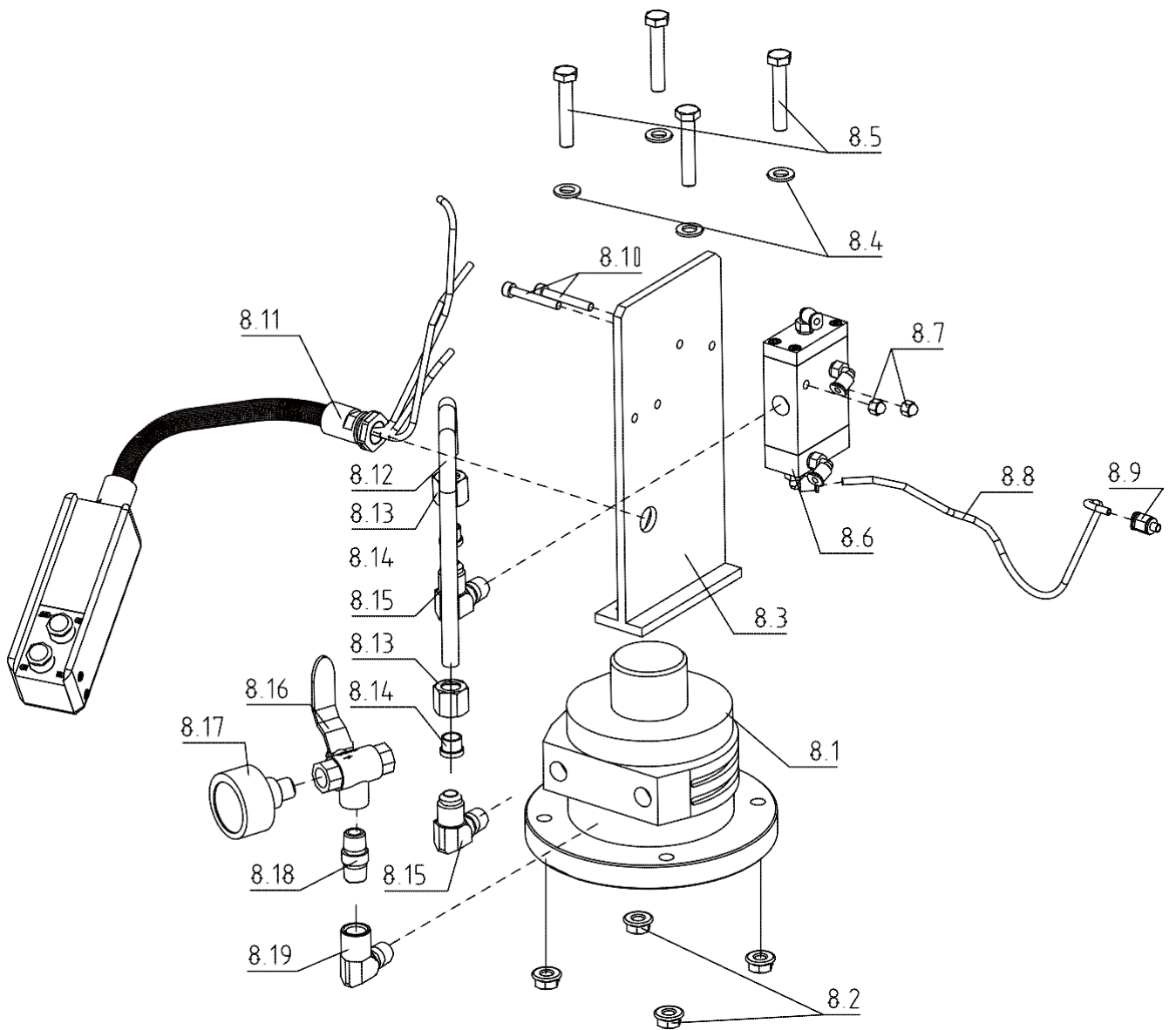

ITEN	NAME	NUM	ITEN	NAME	NUM
8.1	Pneumatic motor parts	1	8.12	Inlet pipe	1
8.2	Nut	4	8.13	Nut	2
8.3	Fixed plate	1	8.14	The village set	2
8.4	Washer	4	8.15	Right angle type joint	2
8.5	Bolt	4	8.16	Three way ball valve	1
8.6	Pneumatic reversing valve	1	8.17	Muffler	1
8.7	Cover type nut	2	8.18	External joint	1
8.8	Trachea	1	8.19	Internal and external joint	1
8.9	Miniature quick coupler	1			
8.10	Screw	2			
8.11	Gas control unit	1			

Pneumatic schematic diagram

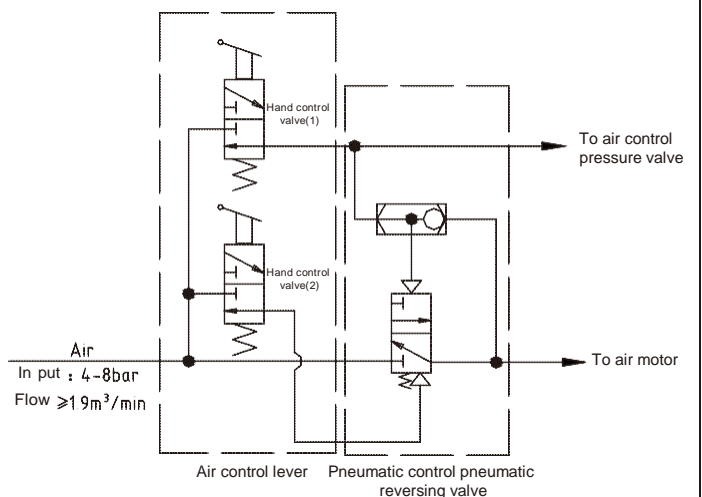

## HYDRAULIC PRINCIPLE

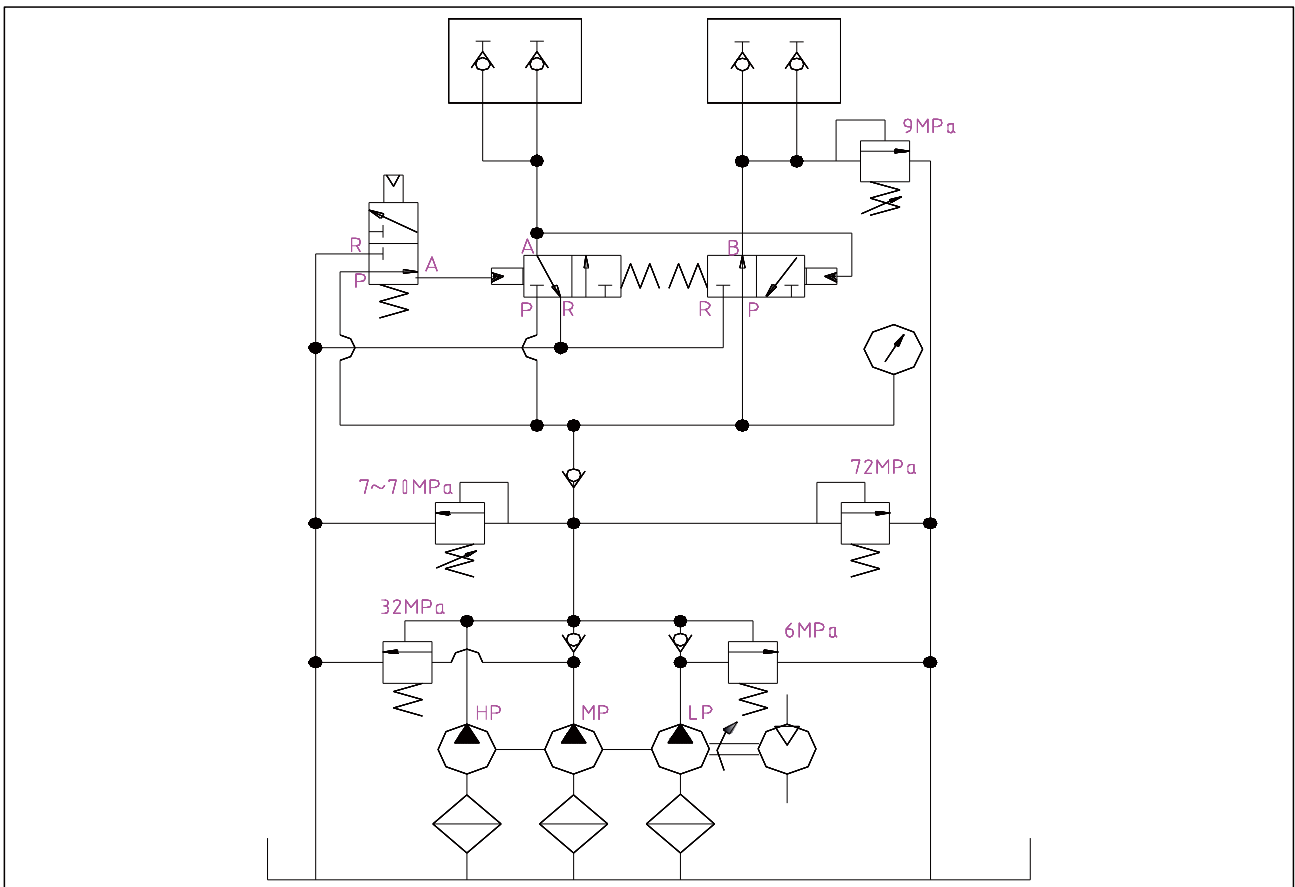

## WARNING FOR USING HIGH PRESSURE HOSE

1. Please use ATW's JH series high pressure hoses.
2. The minimum bending radius:  $R > 120\text{mm}$ . Too small bending radius will destroy the high pressure hoses.
3. The maximum operating pressure is 700 Bar, and it is forbidden to overpass the pressure.
4. Do not tighten hoses excessively. Over tightening can cause to premature thread failure or high pressure fittings to split at a pressure lower than their rated capacities.
5. Should any hydraulic hose rupture, burst, or need to be disconnected, immediately shut off the pump. Never attempt to grasp a leaking pressurized hose with your hands. The force of escaping hydraulic fluid could cause serious injury.
6. Do not use the hose to remove attached equipment. Stress can damage the hose, causing personal injury.
7. Do not subject the hose to potential hazard such as fire, sharp surfaces, extreme heat or cold or heavy impact. Do not kink, twist, or bend the hose so tightly that oil flowing in the hose is blocked or reduced. Periodically inspect the hose for wearing, because any of these conditions can damage the hose.
8. ATW JH series 1000Bar high pressure hose's operating pressure is 1000Bar, Overpass this pressure is forbidden.

## AFTER-SALES SERVICE

1. ATW guarantees quality of the material used for manufacturing products and quality of your technical fulfillment. The guarantee period of the products is 12 months from the date of selling.
2. If any quality issue due to the defects of the materials or craftsmanship is found within the guarantee period. ATW will be responsible and repair or replace the defective products for free.
3. If the equipment is damaged because of happenstance, wrong operating and modifying or repairing the parts without consulting ATW's technical service department, ATW will not guarantee these cases.

# PNEUMATIC PRINCIPLE

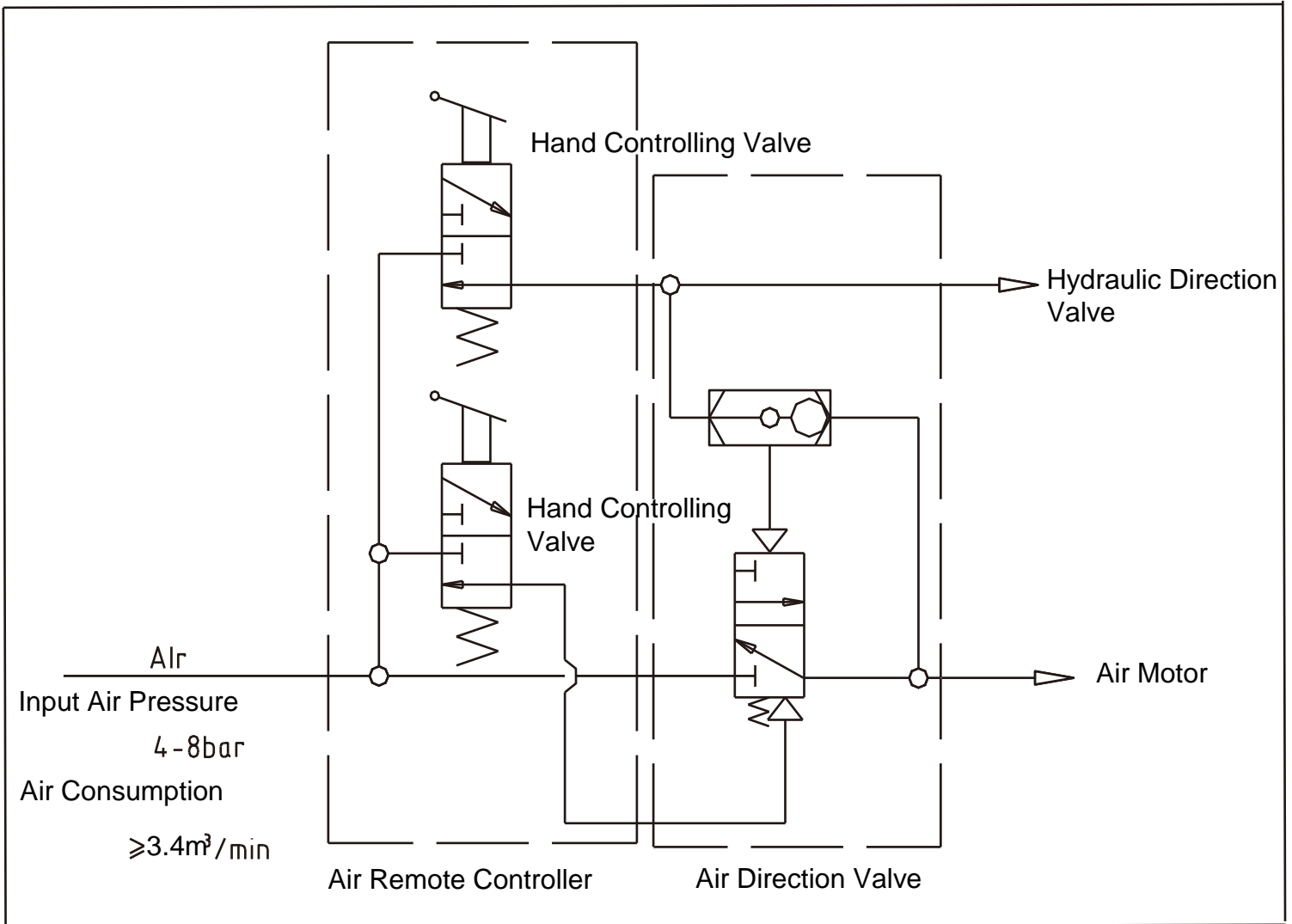

Name	Specification	Remark
Air Direction Valve	HXQ01	
Air Remote Controller	QB02	
Hand Controlling Valve	MJV-3C	
Hand Controlling Valve	MJV-3C	

## Specification & Parameter

Model	Oil capacity ( L )	Operating	Air Motor	Power ( HP )	Flow ( L/min )			Oil outlet connecting thread	oil retrun port connecting thread	Maxwork pressure ( Bar )
					Low	Mid	High			
4VN-2	5.5	AIR	Rotate Speed: 3000r/min Pressure Output: 4 ~ 8 bar Air Consumption: ≥3.4m3/min	4.0	8.2	2.8	1.4	NPT1/4	NPT1/4	700
4VN-4	5.5	AIR	Rotate Speed: 3000r/min Pressure Output: 4 ~ 8 bar Air Consumption: >3.4m3/min	4.0	8.2	2.8	1.4	NPT1/4	NPT1/4	700

**\* 4VN-2 series can be operated with one or two Torque Wrenches.**

**\* 4VN-4 series can be operated with 4 Torque Wrenches.**



All ATW products are guaranteed against defects in workmanship and materials for as long as you own them. Under this guarantee, free repair or replacement will be made to your satisfaction.

[www.atwtools.com](http://www.atwtools.com)

RECYCLED  
PAPER

